

# Cold Gas Thruster Qualification for FORMOSAT 5

By Hans-Peter HARMANN<sup>1)</sup>, Tammo ROMBACH<sup>2)</sup> and Heiko DARTSCH<sup>1)</sup>

<sup>1)</sup>AST Advanced Space Technologies GmbH, Stuhr, Germany

<sup>2)</sup>SpaceTech GmbH, Immenstaad, Germany

Four cold gas thrusters will be used to control Taiwan's FORMOSAT 5 satellite. The thrusters have been developed and qualified by AST Advanced Space Technologies GmbH together with SpaceTech GmbH Immenstaad. The lightweight 43 gram thrusters provides a thrust of 46 mN at 1.5 bar(a) N<sub>2</sub> with an ISP above 69 seconds. Low leakage of below 10<sup>-5</sup> mbar l/s limits the gas loss during off times to a very low level. The thruster can be driven with a wide range of voltages from an unregulated bus and has design that allows an easy adaption to different mechanical interfaces. During the qualification program in 2014 the thrusters have been tested for the mission requirement of one million actuations. Based on the results of a parallel lifetime demonstration test (one billion actuations), it has been decided to extended the qualification program. The extended lifetime qualification is currently running.

**Key Words:** Cold Gas Propulsion, Formosat 5, Qualification

## 1. Introduction

Formosat 5 is a small LEO earth observation satellite of 525 kg mass. Designed and developed by the Taiwanese Space Organization NSPO, it will provide a panchromatic imaging from a sun synchronous orbit at 720 km altitude. The five years mission is planned to be launch on a Falcon 9 rocket in 2016.

NSPO was supported by SpaceTech GmbH Immenstaad (STI) in several fields including the propulsion system. The satellite is controlled by four cold gas thrusters. These thrusters have been design, developed and manufactured by AST Advanced Space Technologies GmbH (AST) especially for the Formosat 5 program. The qualification and acceptance testing has been mainly conducted by STI at their large vacuum test facility.

## 2. Cold gas thruster development

The cold gas thruster (CGT) bases on a miniaturized solenoid valve with low leakage and a unique lifetime capability. It has been converted and prequalified for space applications in a xenon flow control development program ("μFCU")<sup>1)</sup>. <sup>2)</sup> funded by the European Commission.

The development of the CGT has been initiated on the request of SpaceTech GmbH. As the satellite design was already frozen, the thruster design had to fit into the specified geometric envelope and electrical properties and operational schemes had to be met.

The development itself has been carried out in less than 2 years including an EM phase, FM production and qualification starting in February 2013.

### 2.1. Design

The CGT consists of the solenoid valve, a nozzle, a mechanical interface plate and the fluidic interface. The

Table 1. CGT key figures

mass	43 gram
nom. thrust	46 mN @ 1.5 bar N <sub>2</sub>
specific impulse	>69s
switch on time	<1ms
op. voltage range (pull-in)	22 to 36 V
resistance	140 Ohm
min. power (pull-in / hold)	3.5 W / 0.1 W (typ. 0.25 W)
temperature range	-25°C to +60°C
lifetime actuations	1.5 million (qualification) 1.1 billion (demonstrated and under qualification)

modular configuration allows the change of the nozzle diameter or the fluidic interface without modifications of the other parts.

The nozzle design was supported by the Deutsches Zentrum für Luft-und Raumfahrt (DLR) at Göttingen. The DLR used their simulation tools to predict the flow characteristic and the performance of the CGT. EM tests to verify the simulations have been carried out at one of DLR's vacuum chambers. These tests included thrust measurements on a thrust balance<sup>3)</sup> to determine the specific impulse and the investigation of the "thrust on" delay using a Pitot probe. As best compromise a 15° cone nozzle with 0.6 mm throat diameter has been chosen.

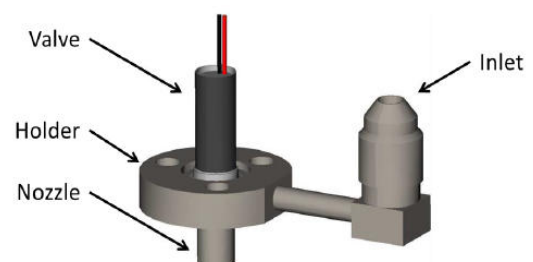

Fig. 1. AST's cold gas thruster design

## 2.2. Performance

The basic performance characterization has been done using EM thrusters that were identical to the FMs but produced in a first pre-series production step. The thruster was mounted on top of a thrust balance capable to measure thrusts between 0.1 mN and 1000 mN (figure 2). Then a set of firing demonstrated the good reproducibility of the thrust level. From the repeated measurements the specific impulse has been derived as 70.4 seconds at nominal inlet pressure of 1.5 bar.

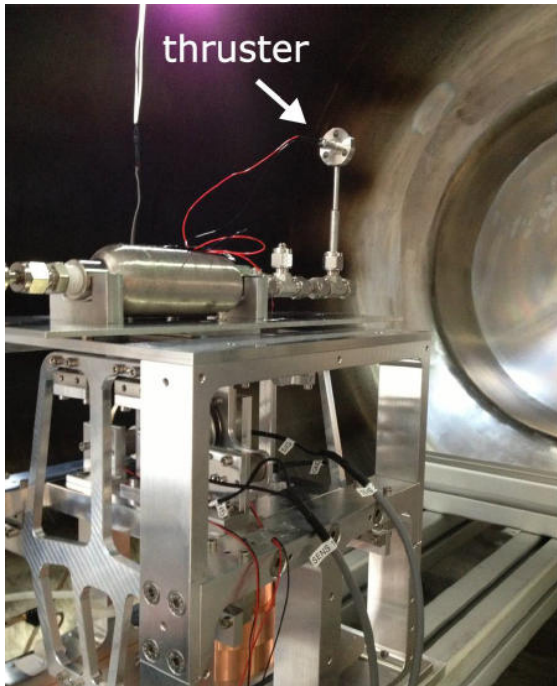

Fig. 2. CGT EM on top of thrust balance at DLR

Table 2. Thrust measurements for  $I_{sp}$  determination

Thrust mN	Mass Flow mg/s	$I_{SP}$ s
42.6	61.6	70.4
42.3	61.6	69.9
42.6	61.6	70.4
42.3	61.6	69.9
42.5	61.6	70.3
43.1	61.6	71.2
42.8	61.6	70.7

$$\text{Average } I_{SP} = 70.4 \text{ s} \pm 0.5 \text{ s}$$

The thrust and the  $I_{sp}$  for a given mass flow at constant temperature is defined by the nozzle geometry. As all nozzles are manufactured in a reproducible and precise way, the  $I_{sp}$  is assumed to be valid for all thrusters of this configuration. For the further measurement campaigns only the mass flow has been monitored to determine the equivalent thrust level.

## 3. Operation

The thruster operational profile for Formosat 5 was already defined as AST started the development. The thruster is

operated in pull-in / hold mode with a fixed pull-in time of 50 ms. The minimum pull-in time is defined as 2.5 ms.

The CGT is designed for a pull-in voltage between 22V and 36V and a hold voltage above 6 V to allow the supply from an unregulated bus.

## 5. Manufacturing

A batch of ten thrusters has been manufactured for the Formosat 5 project. One was used for production process monitoring. Four flight models (FM), one flight spare and one qualification model have been delivered to STI for acceptance and qualification testing. These thrusters have been selected from the batch for best matching of the mass flow. By the selection process the variation between any FM is less than 1.3% while the maximum allowed variation is 5%.

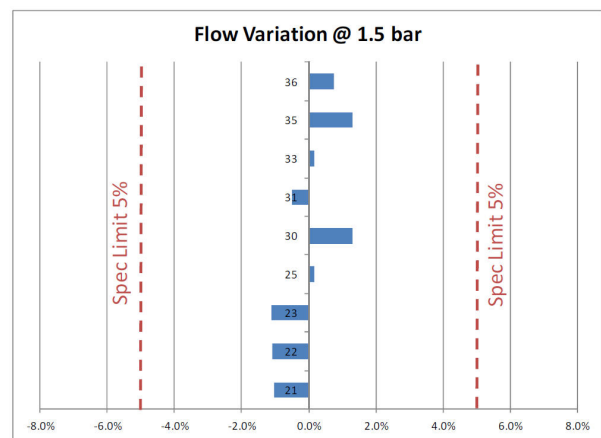

Fig. 3. Mass flow variations within the series production batch

The CGTs have been fully welded with electron beam welding and laser welding processes. The electrical interface has been vacuum potted. In a final step before delivery each thrusters has been precision cleaned and dried.

After delivery, STI added a diode clamping circuit to the CGT harness.

## 4. Qualification and acceptance testing

### 4.1. Test philosophy

A valve similar to the one used for the CGT had already demonstrated its capabilities and quality within the flow control development program. These tests included a lot of margin compared to the requirements of Formosat 5.

It has been decided to do the acceptance test and the qualification test in one shared test. The FMs are tested to acceptance level while the QM is tested with additional margins.

Core parameters of the CGT have been verified twice. Once at AST in the frame of a factory acceptance test and the second time within the official acceptance and qualification test performed by STI.

The acceptance and qualification program includes

- function performance tests including electric parameters and insulation test
- leakage test (repeated between individual tests)

- proof pressure test
- thermal balance and thermal cycling test (TV)
- vibration test

After the qualification tests the QM has been sent to AST for lifetime test. The lifetime test has been carried out in AST's vacuum facility for a total of 1.5 million actuation cycles (incl. 50% qualification margin).

#### 4.2. Functional and performance tests

The mass flow depends linearly on the inlet pressure. During the acceptance tests the pressure has been varied between 0.8 bar and 5 bar covering an equivalent thrust range between 25 mN and 160 mN.

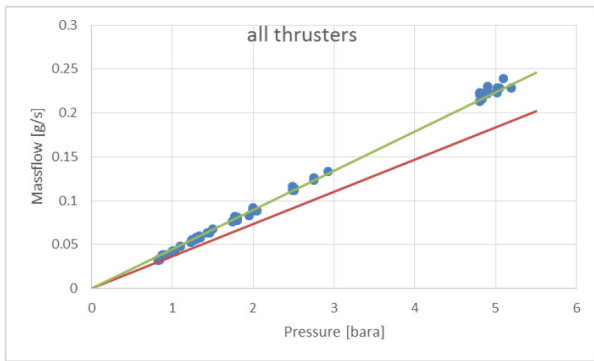

Fig. 4. Linear flow response to inlet pressure for all tested thrusters. The green and the red lines showing the thrust requirement range.

The functional and performance test also includes the electric insulation test and the determination of characteristic parameters as set-on voltage, hold voltage and switch times. The switch times have been measured electrically. The acceleration of the valve armature as it hits the rest induces a voltage that drives a current. In the current time diagram the impact is visual as small dip.

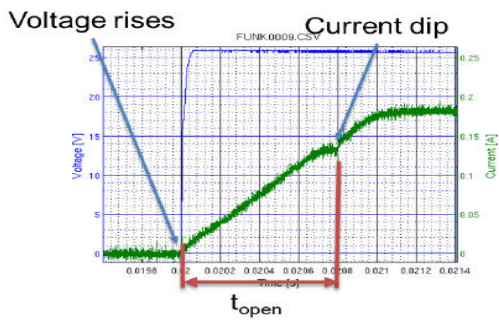

Fig. 5. Determination of the switch on time

The switch time and the electric parameters are sensitive probes for changes or failures in the internal mechanics of the valve or in its magnetic circuit. If the force of the spring, the magnetic force or dimension between components change then the set-on/set-off voltages and the switch time will shift. Therefore the switch times have been measured for each thruster after each intermediate test.

Figure 5 shows the switch times for different pressures and

voltages exemplarily for one valve (S/N 30 QM) throughout the full acceptance and qualification test campaign. The small number at each entry give the voltage level. The switch time depends slightly on pressure and voltage but stays unchanged after all stress tests.

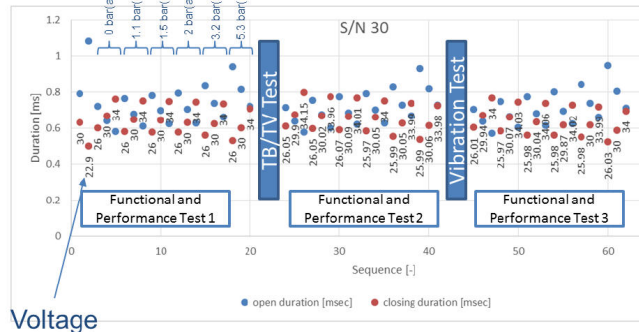

Fig. 5. Switch time stability of CGT S/N 30 (QM) during qualification test

A further parameter monitored through the test campaign is the mass flow and respectively the thrust of the CGT. This parameter remained very constant over the full test campaign. All requirements have been met.

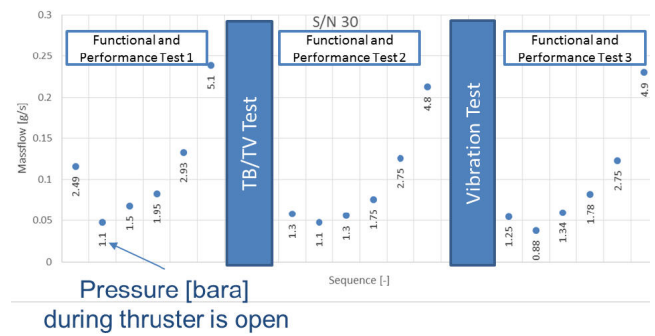

Fig. 6. Mass flow stability of CGT S/N 30 (QM)

#### 4.3. Leakage test

The leakage requirement defines a limit of  $2 \cdot 10^{-5}$  mbar l/s GHe. The measured leakage values (helium leak tester) were measured as being below  $10^{-6}$  mbar l/s. This very low leakage was not influenced by any stress test. Figure 7 shows the measure leakage levels (small numbers give the serial number of the CGT). The variation are resulting from measurement uncertainty in the  $10^{-7}$  mbar l/s range.

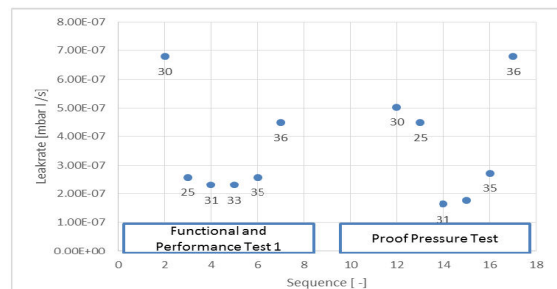

Fig. 7. Leakage stability of all thruster

**4.4. Proof pressure test**

For the proof pressure test an inlet pressure of 6.5 bar(abs) was applied. Before and after the test the electric parameters, the switch time and the leakage has been measured.

**4.5. Vibration test**

While the EM flow control unit had been tested to levels of up to 21.5 gRMS the Formosat 5 requirements for the CGT were much more relaxed. It has been considered as no risk to test all thrusters in parallel to qualification level. The six thrusters have been mounted on a representative support structure including a flight similar pipework.

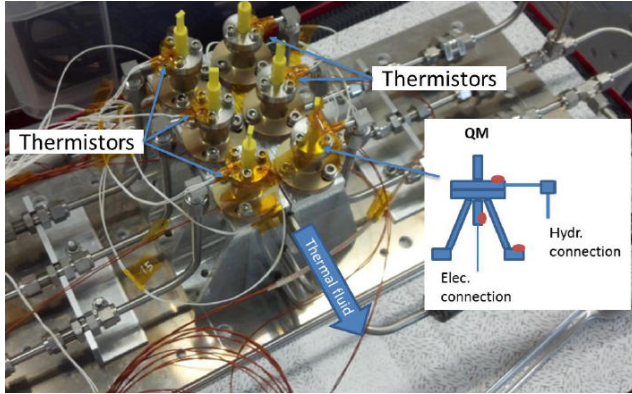

Fig. 8. Test set-up for thermal vacuum test and vibration test at STI

Table 3. Vibration levels of random vibration test (top: in plane, bottom: out of plane)

sensor position	model	g-rms value test	g-rms value qualification	g-rms value acceptance
1y	QM	13.1	12.2	8.7
2y	FM	14.4	12.2	8.7
3y	FM	13.4	12.2	8.7
4y	FM	12.7	12.2	8.7
5y	FM	12.4	12.2	8.7
6y	FM	12.3	12.2	8.7

sensor position	model	g-rms value Test	g-rms value qualification	g-rms value acceptance
1x	QM	17.1	17.3	12.2
2x	FM	15.4	17.3	12.2
3x	FM	17.7	17.3	12.2
5x	FM	17.4	17.3	12.2
6x	FM	18.1	17.3	12.2

During vibration the leakage has been measured by monitoring the pressure decay in the pressurized system. All thrusters survived the test without pressure loss and without any changes in the electric parameters or switch times. The alignment of the thrusters has been determined with a mirror and an autocollimator before and after the vibration test. The potential variation stayed within the measurement error of 0.2°.

**4.6. Thermal vacuum test**

During thermal vacuum test the CGT performance for the operational and non-operational temperature range has been determined. For thermal stress investigation eight temperature cycles have been performed under vacuum.

The FM acceptance test applied operation temperatures between -20°C and +50°C and non-operational temperatures

between -30°C and +60°C. The QM was operated at the elevated range to cover the required test margins. During the former EM flow control development program the valves showed their viability for operational temperatures between -40°C and +80°C.

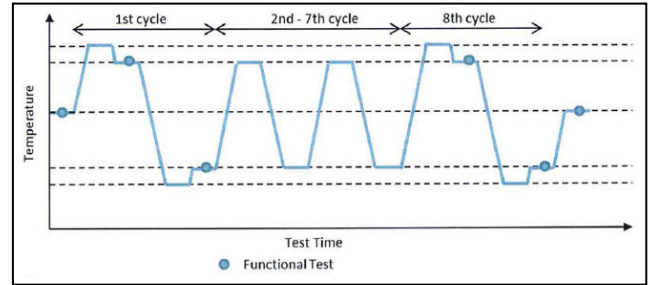

Fig. 9. Temperature cycle profile

**4.7. Lifetime test**

During the former EM test campaign the CGT demonstrated a total of 1.1 billion actuation cycles without failing. For the Formosat 5 project "only" 1.5 million cycles are required including 50% qualification margin.

The lifetime test has been performed within AST's vacuum facility (50 cm diameter). The thruster has been fired under representative conditions with nominal nitrogen mass flow and nominal pull-in / hold operation.

Each 50K cycles (later 100K) the pulsing has been stopped for leakage, switch time, electric parameter and mass flow tests. After the test the pulse operation continued.

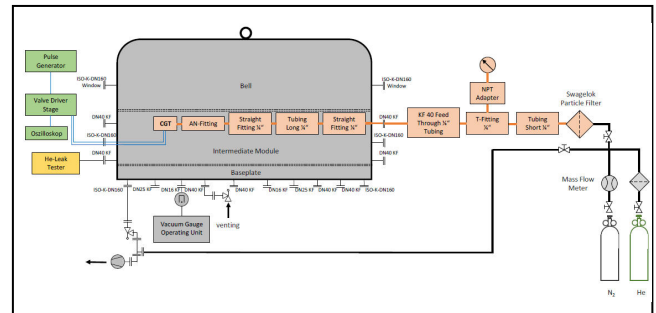

Fig. 10. Test set-up of lifetime test at AST

For the tested 1.5 million actuation cycles no variation or drift of the measured parameters beyond the measurement noise have been found.<sup>4)</sup>

After the lifetime test the QM has been put to storage for a long term storage test (not part of the qualification) of about one year. Then the QM shall be reinstalled into the vacuum chamber to continue the lifetime test in an extended qualification.

**5. Summary and conclusion**

Five FM thrusters and one QM have been successfully tested. All requirements have been verified and met. The operation of the AST CGT has been proven to be very stable and reproducible. The FMs have been delivered and integrated into the Formosat 5 satellite waiting for the launch expected in 2016.



## 6. Outlook

After the qualification according the Formosat 5 specification an extended qualification program using the QM is planned. This program shall qualify the CGT for higher lifetime cycles that already have be demonstrated on EM level<sup>4)</sup>.

## Acknowledgments

We would like to thank "Deutsches Zentrum für Luft- und Raumfahrt Göttingen (DLR)" for their kind support in developing and testing the cold gas thruster.

## References

- 1) Harmann, H.-P. et. al.: *μFCU - A Miniaturized Flow Control unit for Xenon*, IEPC-2013-227, 33rd International Electric Propulsion Conference, Washington D.C., USA., Oct. 2013
- 2) Rothaus, S. et. al.: *μFCU - Results of a Prequalification Test Campaign*, IEPC-2013-228, 33rd International Electric Propulsion Conference, Washington D.C., USA., Oct. 2013
- 3) Harmann, H.-P., Dartsch, H., Werner, E. *Low Drift Thrust Balance with High Resolution*, IEPC-2015-257, 34rd International Electric Propulsion Conference, Kobe, Japan, July 2015
- 4) Harmann, H.-P., Dartsch, H. *Lifetime Test of a Cold Gas Thruster*, ISTS-2015-f-35, 30th International Symposium on Space Technology and Science, Kobe, Japan, July 2015